

Elevate Dual Monitor Arm⁵⁸

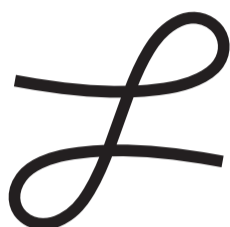

FORMINGFUNCTION . SE

PARTS AND TOOLS PART 1

(A)	x1 PCE			
(B)	x1 PCE			
(C)	x4 PCS	M4x10	NOT NEEDED FOR DUAL MONITOR ARM	
(D)	x4 PCS		NOT NEEDED FOR DUAL MONITOR ARM	
(E)	x4 PCS		NOT NEEDED FOR DUAL MONITOR ARM	
(F)	x1 PCE	2mm		
(G)	x1 PCE	5mm		
(H)	x1 PCE	6mm		
(I)	x1 PCE	NOT INCLUDED		

Before installation: Please follow the instructions. If there is a step you don't understand, please contact your sales representative. Note that all measurements and conditions must be verified on site. Neither Forming Function nor any of its distributors can be held liable for product malfunction or other defects caused by improper installation.



FORMINGFUNCTION

STEP 1

Loosen the two upper set screws in the table clamp and remove them. Remove the arm. Set the arm and set screws aside, they will be reinserted in STEP 3.

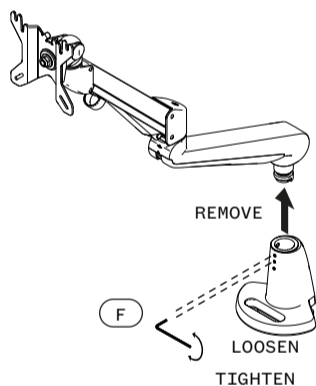

STEP 2

Turn the table clamp upside down, and adhere the rubber pad (B).

Turn the table clamp over again. Loosen the center bolt enough so that the clamp fits around the edge of your table.

Once in place around the edge of your table, tighten the center bolt using Allen Key (H) until you feel resistance.

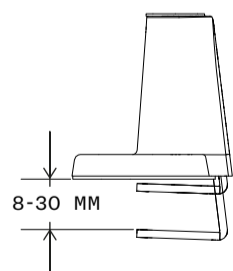
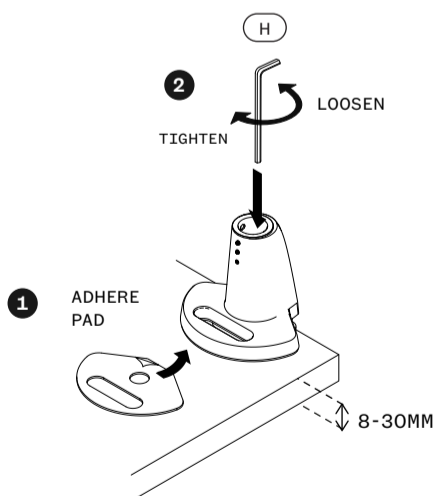

STEP 3

Reinsert the arm in the table clamp and reattach the set screws from STEP 1.

Tighten the middle screw fully, and then loosen it one turn.

Check that the arm cannot be removed.

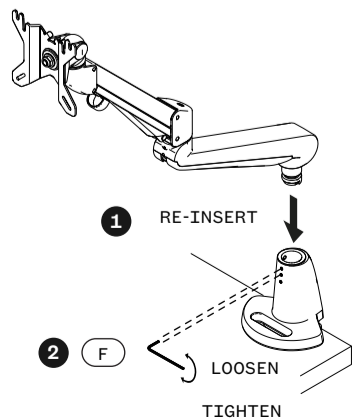

TENSION ADJUSTMENTS AND ROTATION LOCK

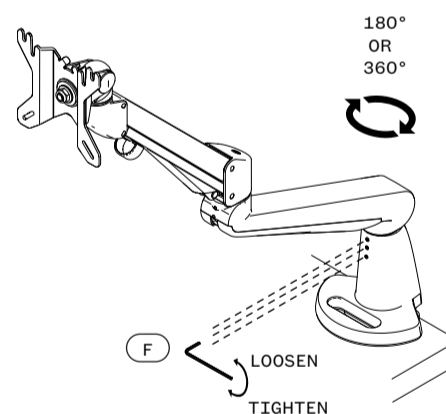

Adjust the tension of the rotation to your need by tighten or loosen the top screw.





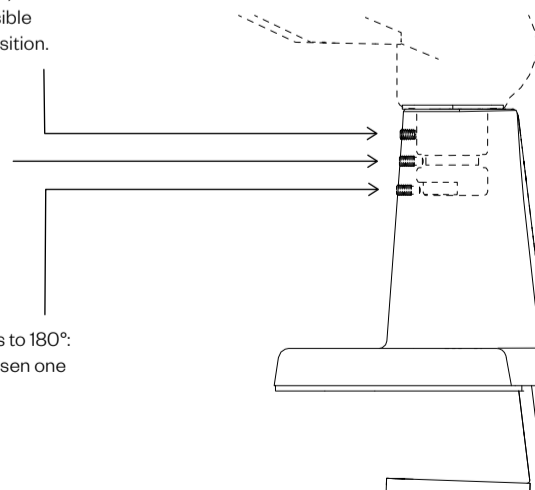

To keep the arms completely rigid, fasten the the top screw as tight as possible while maintaining the intended position.

Fasten and loosen the middle screw one revolution to prevent the monitor arm from being removed.

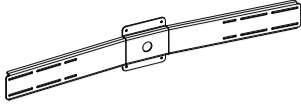
To limit the rotational movements to 180°: Fasten the bottom screw and loosen one revolution.



PARTS AND TOOLS PART 2

(J)	x1 PCS	
(K)	x2 PCS	
(L)	x12 PCS M4x12	
(M)	x4 PCS	
(N)	x4 PCS	
(O)	x8 PCS	
(P)	x1 PCS 13 mm (NOT INCLUDED)	

STEP 4

Mount the Dual bar to the arm. Lift the bar into monitor and pass the screws (L) through one by one. If necessary use the washers (M) and fasten using the using the nuts (N).

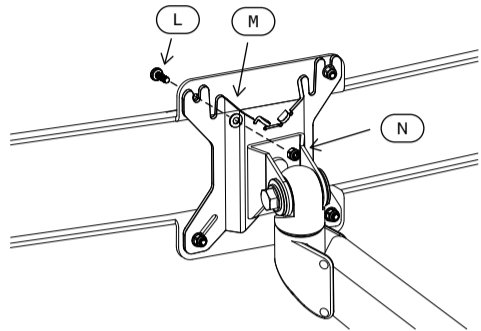

Place the monitor face down on a flat surface. Align the VESA on a flat surface. Align the VESA bracket (K) holes and fasten using screws (L). Repeat procedure for both monitors.

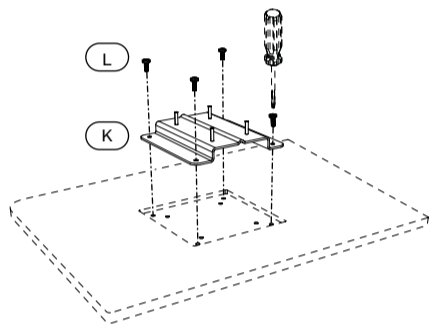

STEP 6

Unattach the cable collector and route the cables through. Once satisfied, re-attach the collector back into place. Proceed by continuing the routing through the cable clip.

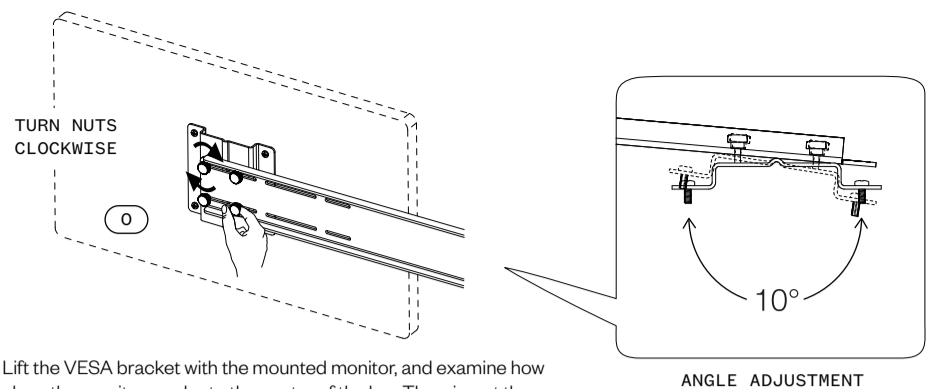
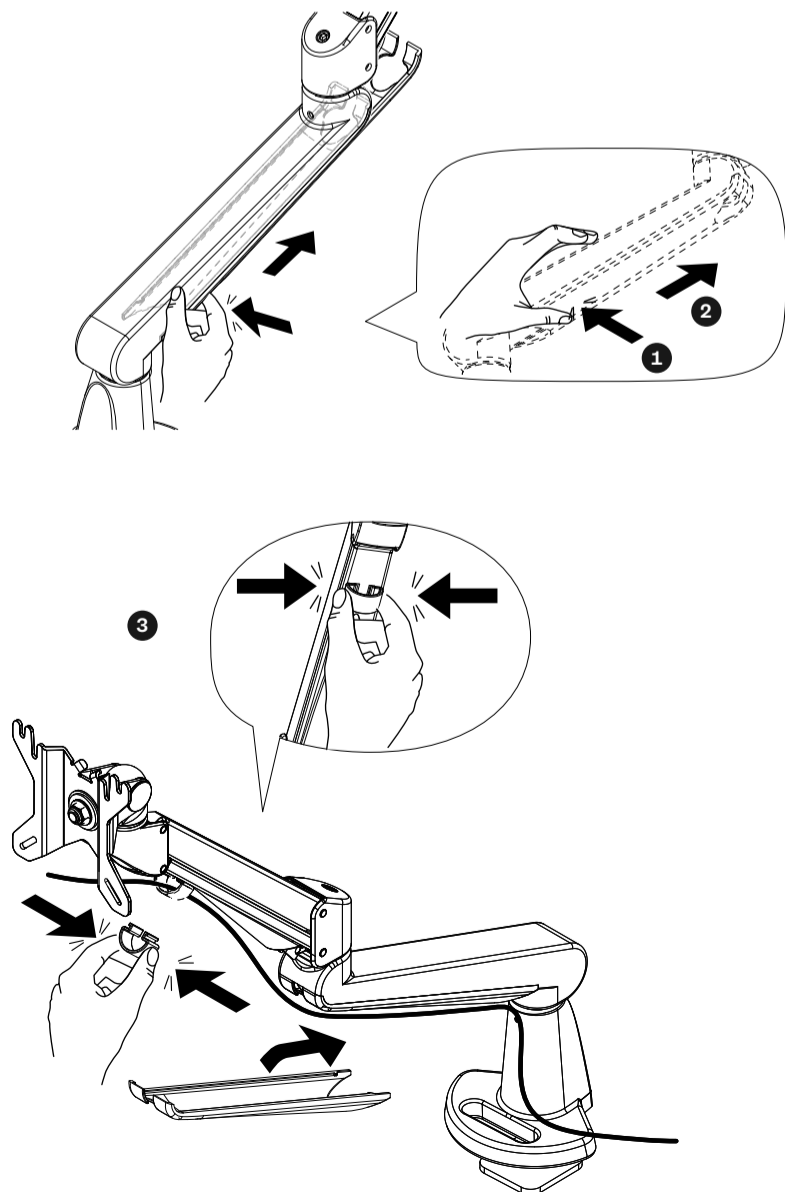

Lift the VESA bracket with the mounted monitor, and examine how close the monitor can be to the center of the bar. Then, insert the VESA bracket pins into the track of the bar and lock them to the track using the knob nuts (O). Angle the monitor as you see fit. Repeat procedure for both VESA brackets.

STEP 5

Use wrench or impact wrench to tighten the bar to a vertical position, until fully rigid. Hold it up to the desired position and use the VESA bracket or bar as a gripping surface to counter the force of the wrench and gravity. This step is easiest if you are two persons:

! DO NOT SKIP THIS STEP

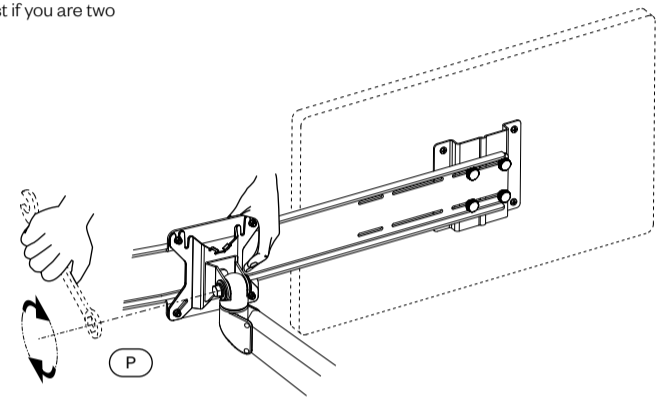

TENSION ADJUSTMENTS

CAUTION:
Support and hold on to the arm while adjusting the tension.

ADJUSTMENT:
Use the Allen key provided to adjust the tension to correspond to the weight of the desired monitor. Turn the Allen key counter-clockwise to adjust for heavier monitors; clockwise for lighter monitors. Once the adjustment is done, the monitor should be experienced as weightless and the monitor should remain in any position without dropping nor rising.

RECOMMENDATIONS:

- 8-14 kg.
- The products loading capacities are based on monitors' center of gravity less than 3 cm from the end of the VESA interface.
- Loading capacity could be reduced if the monitor size is greater than 26" or if the thickness exceeds 5.5 cm.
- All product specifications in catalogues are subject to change without notice.

