

ELEVATE DUAL MONITOR ARM⁵²

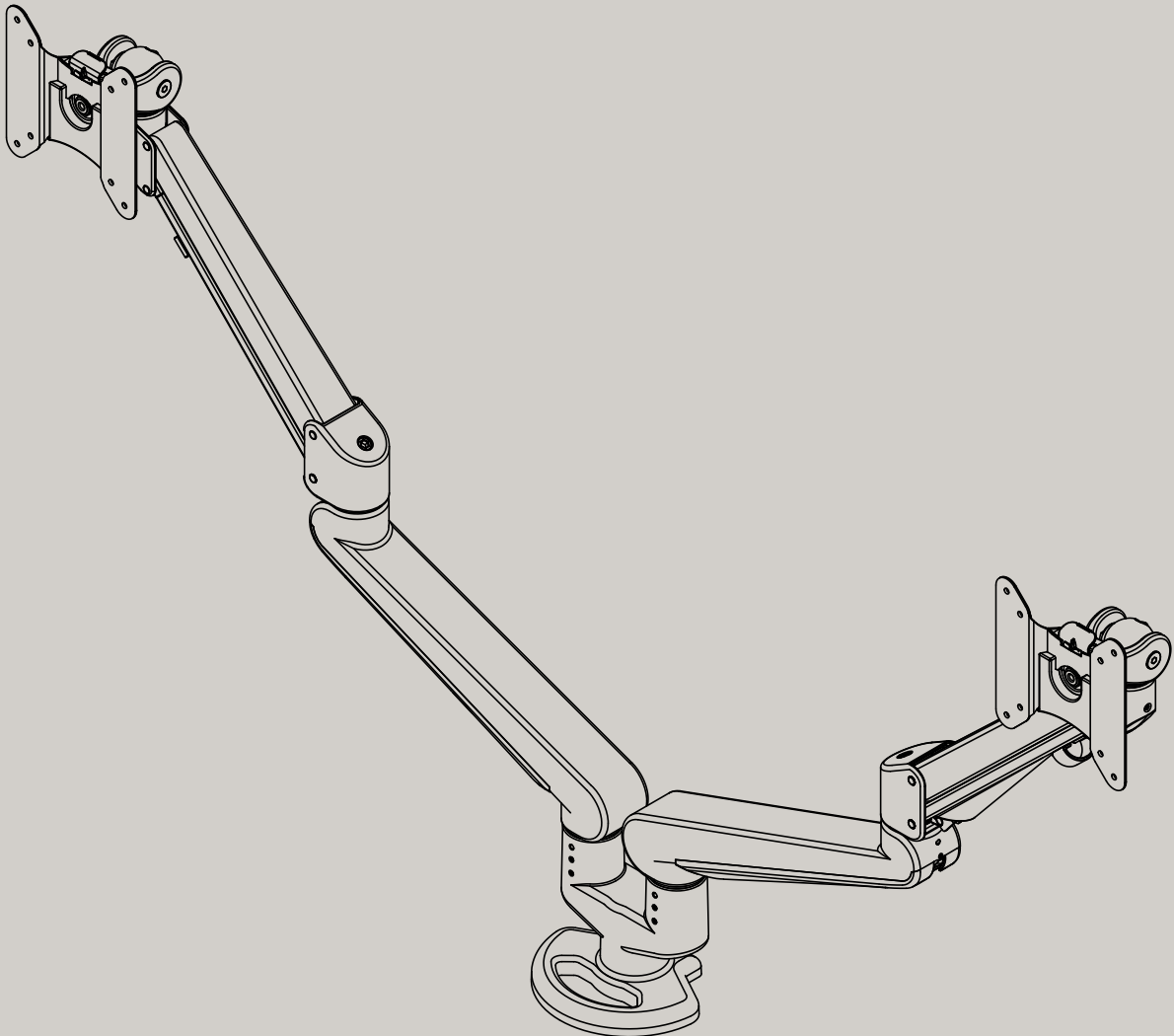

Dimensions

See user manual for assembly instructions

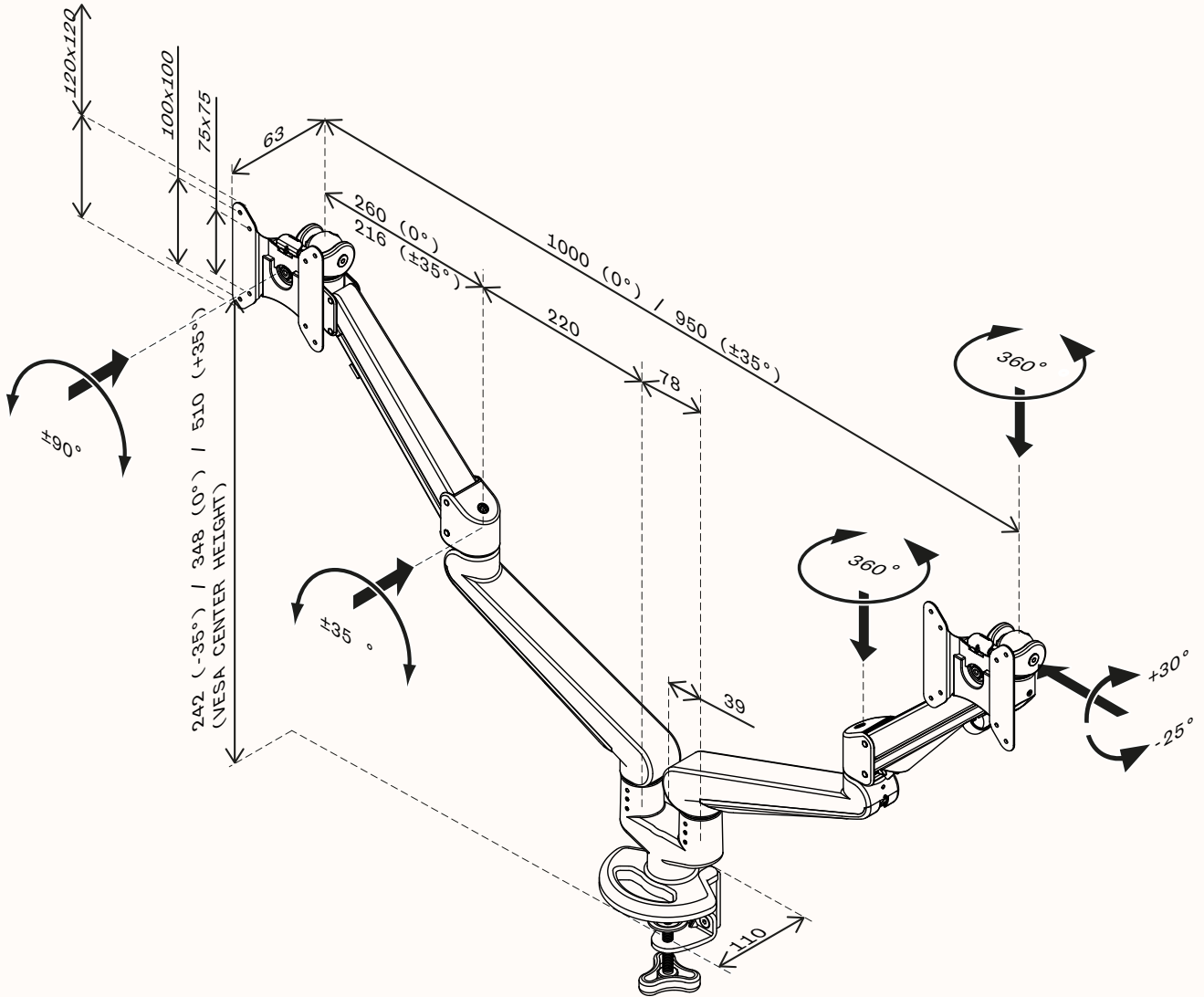

ALTERNATIVE GROMMET CLAMP

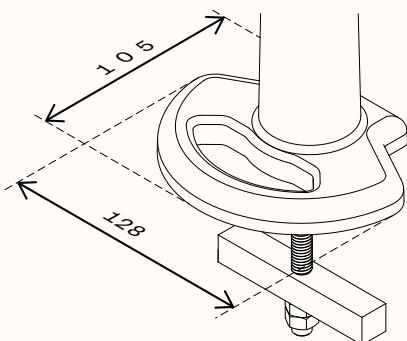

RANGE FOR TABLE THICKNESS

- 16-50 mm (REGULAR CLAMP)
- 0-36 mm (GROMMET CLAMP)

MAXIMUM RECOMMENDED MONITOR WIDTH

- (2x) 992 mm

ELEVATE DUAL MONITOR ARM⁵²

3-8 KG, GAS SPRING, BLACK/WHITE/SILVER

ART. NO

4385515209	BLACK	RAL9005
4385515201	WHITE	RAL9016
4385515202	SILVER	RAL9006

Technical data

MATERIAL	ALUMINIUM AND STEEL
FINISH TYPE	POWDER COATED
FINISH	BLACK/WHITE -MATTE, SILVER-METALLIC
MAXIMUM ARM LENGTH	486mm
WEIGHT RANGE	3-8kg*
VESA	75/100mm
MAX TABLE THICKNESS	16-50mm

* Weight span is calculated based on monitor with Centre of Mass shorter than 30mm from VESA interface. For curved or bigger screens, the weight span might differ.